

Uninterruptible
Power Supplies
Catalog UPS - Series E₁

UPS Systems
6 kVA to 20 kVA

MASTERGUARD protects	2
Areas of application for Series E ₁	3-4
MASTERGUARD Series E ₁	
Description	5-6
Technical data, ordering data	7-10
Dimensions	11
Conditions of sale and delivery	12

UPS Systems Series E1

MASTERGUARD protects

No matter how dirty your electrical power system might be, MASTERGUARD protects it. This Uninterruptible Power Supply provides on-line double conversion technology to ensure highest power security and reliability. So MASTERGUARD equalizes all irregularities in the electrical power system. It makes brief power disruptions harmless, and at the same time has enough reserves to bridge prolonged mains failures (Fig. 1).

Typical applications:

- DP equipment and systems
- Personal computers
- Workstations
- Small office/home office sector (SOHO)
- Servers and networks
- Computer centres
- Process controls
- Control centres
- Telecommunication systems
- ISDN systems
- Drives in continuous production processes
- Production and automation systems
- Life-support systems in hospitals
- Air-traffic control systems
- Safety systems in power stations
- Broadcasting studios
- Transport systems
- and many others

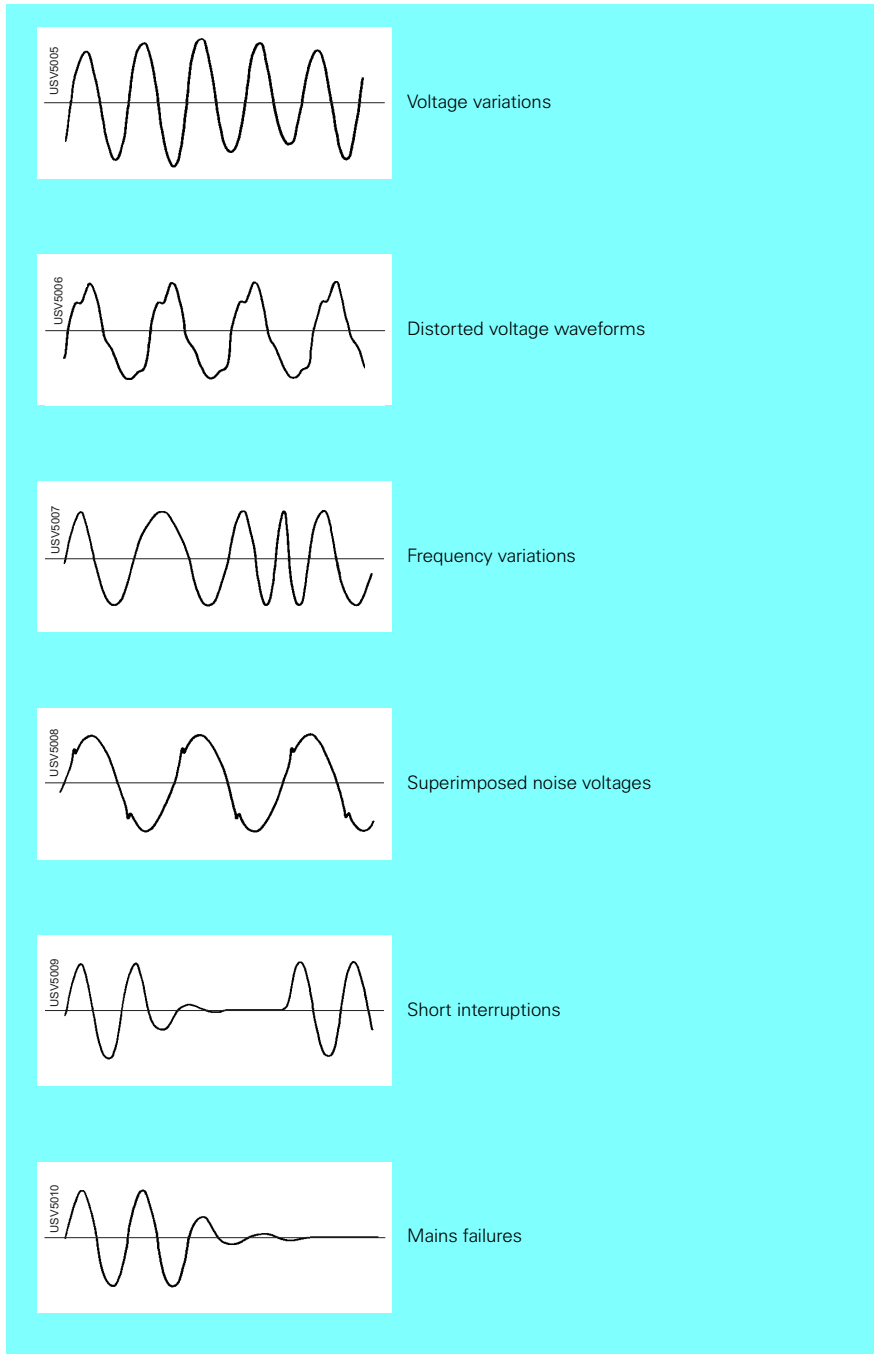
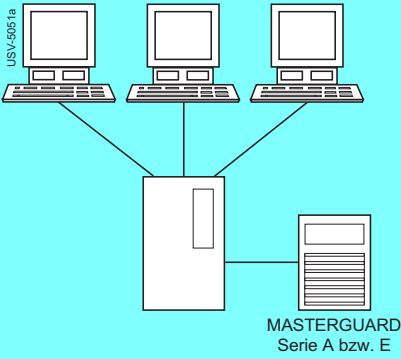

Fig. 1
Types of mains disruptions

MASTERGUARD Series E1
protects all single-phase loads up
to 20 kVA

Areas of application for Series E_I in the computer world



Multi-user systems
Minicomputer-based, e. g.

- Primergy, MX 300/500, RM 300/400/600 (SNI)
- AS/400 (IBM)
- VAX (DEC)

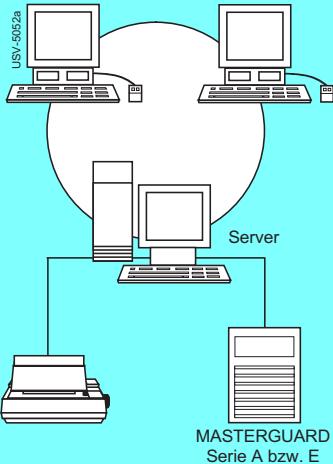

Networks

- Windows NT
- Novell Netware
- UNIX
- IBM LAN

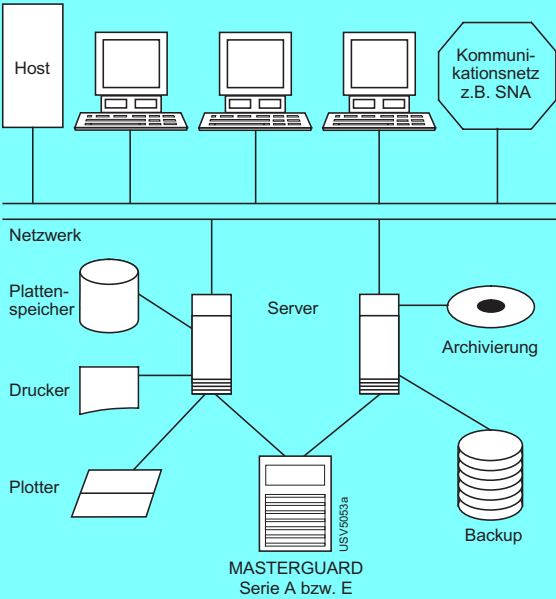

Server applications

- SQL-database system
- SAP-application
- WEB server
- RAID systems
- Cluster systems
- eCommerce

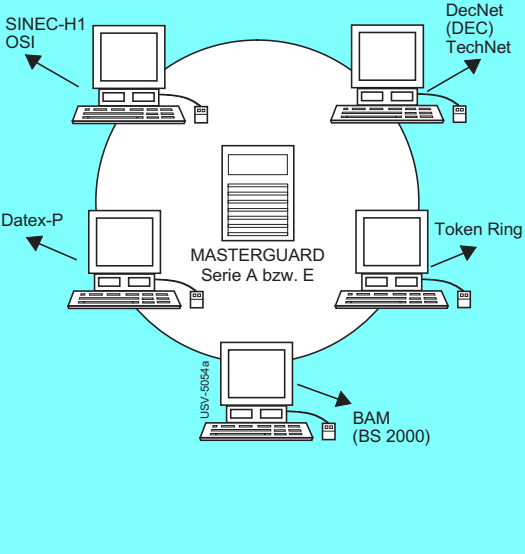

Exchange equipment/nodes
between different networks/structures, e.g.

- ATM
- Firewall system
- DecNet (DEC)
- Transdata (SNI)
- Datex-P, X.25

UPS Systems Series E

Areas of application for Series E

Computer environments

- Network servers
- PC systems in computer networks
- Workstation systems
- Application and database servers
- Control and automation systems in the factory and production

Critical areas of application

- For multimedia
- For Internet banking
- For provider applications
- In database systems
- For batch functions
- For data backup
- In archiving systems
- For animation, kinematic
- For long calculations (e.g. FEM), simulations

Our Technology	Benefits For You
True on-line operation – load is fully disconnected from the mains	<ul style="list-style-type: none"> • Power failures bridged completely without interruption • Consistently good quality of power supply • Safe operation of sensitive loads
Small, light, low noise emissions, modern office design	<ul style="list-style-type: none"> • Problem-free installation at the workplace • Unit supplied ready for connection
Integrated, automatic bypass	<ul style="list-style-type: none"> • Short-circuit and overload proof • High degree of availability of output voltage
Computer interface in unit	<ul style="list-style-type: none"> • Communication possible with computers
UPS management software (accessory) for intelligent responses during prolonged power failures as well as for UPS monitoring	<ul style="list-style-type: none"> • Integration in SNMP networks • Multi-server shutdown • UPS and computer – one system • No data loss, no system crashes • Configurable computer shutdown • Can be operated with all major operating systems and networks • Controllable via Internet browser when connected with a Web-server capable SNMP adaptor
Ergonomic design	<ul style="list-style-type: none"> • No operator control required while running • Clear indication of states and load by LEDs, as well as by acoustic alarms if faults occur
Fast service (tailored to your needs)	<ul style="list-style-type: none"> • Minimal down-times • Pick-up and return delivery service • Ecologically compatible disposal • Replacement units available immediately

Description

Operation

The UPS units operate according to the true on-line principle, i.e. connected loads are isolated from the irregularities of the mains supply without interruption and supplied instead by the UPS.

The rectifier, which converts the mains AC voltage to DC voltage, supplies the inverter with power during normal operation. At the same time, the battery is maintained at full charge or is recharged if it has been discharged (see block diagram).

The inverter generates the sine-wave output AC voltage, whose level and frequency are stable, from the DC voltage.

This double voltage conversion isolates the load from the mains and thus protects it from the following irregularities:

- Voltage variations
- Frequency variations
- Overvoltage/undervoltage
- Voltage peaks
- Interference voltages
- Distorted voltage waveforms.

If a short interruption or mains failure occurs, the battery supplies the inverter instantly and without interruption. When power is restored during battery operation, the changeover to normal operation likewise takes place without interruption.

As no switchover is necessary when power fails or is restored (on-line operation), this UPS unit ensures that even sensitive loads can be operated safely and without any problems. If severe or prolonged overloading, a load short-circuit, overvoltage or undervoltage levels at the output or UPS faults occur, the UPS automatically switches to the integrated bypass. The mains power at the UPS input is then available.

- True on-line operation

Features

- True on-line operation, i.e. complete isolation of the load from the irregularities of the mains supply
- Wide input voltage range for optimal battery care
- Optimum system security ensured by integrated service-switch, electronic bypass and emergency-power-off-interface
- High-quality sine wave voltage at the output
- Sine wave input current
- PWM inverter technology

- Compact design, small dimensions
- Battery expansion with parallel battery cubicle, e.g. for 3 h back-up time at 7 kVA load
- Light weight achieved by using modern technology
- Castors allow easy positioning on site
- Simple operation and functional indicators for displaying operating states and load levels
- Integrated interface and optional communication software for computer operation
- Extension-slot for the easy installation of optional interface cards
- Service switch to allow service operations without shutdown
- Emergency-power-off-interface to integrate the UPS in an emergency-power security system
- Integrated, automatic bypass increases availability
- Installation is easy

Interface

Integrated combined interface (COM A) for:

- Response of a connected computer to power failures and UPS operating states (e.g. shutdown), or
- Monitoring the UPS with a computer/server
- UPS management with additional software
- Monitoring the UPS with a signalling system



Fig. 2 UPS unit MASTERGUARD E₁ 60

Options

With special options the Series E₁ can be adapted to a great variety of customer-related configurations:

- External manual bypass switch as well as communication packages for the most common computer and network operating systems
- SNMP-adaptor cards for interface slot
- SIC-interface card for signal communication
- Shutdown software
- MultiCom-connection for the LIFE2000-surveillance

- Security at every time: Manual service-switch and EPO-Interface

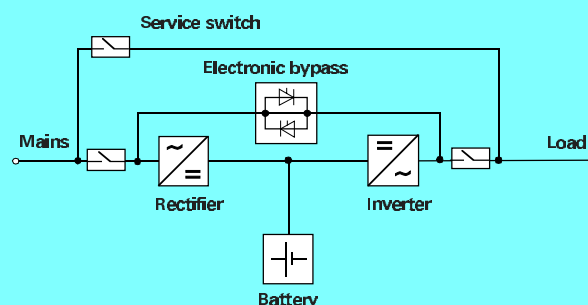

Fig 3 Block diagram of the on-line double conversion UPS Series E₁

Description

Performance if the interface is used

The UPS unit is equipped with an interface that is designed for communication with a computer. If the connected computer is informed of a power failure, for example, via this interface, it can shut down its programs and the operating system in a controlled and orderly manner within the battery's back-up time.

The computer/server requires an RS 232 interface for communication with the UPS unit. Optional standard software available for all major operating systems and for networks monitors the UPS status, generates alarm signals and shuts down the computer automatically.

Please refer to the description of Power-Protect NET for further information about the UPS management software.

Interface assignment as for Series A (see page 7).

Battery expansions

The E₁ 60 to E₁ 200-3 UPS units can be expanded with parallel battery cubicles. Back-up times of several hours can be achieved in part-load operation.

Installation

The UPS units and the battery cubicles can be positioned easily on site thanks to the castors mounted underneath them. They can be locked in their final position by means of height-adjustable feet.

Connection

The UPS unit is ready for connection. All the connections can be found at the rear of the unit. They are clamp-type connectors according to IEC 320 for the mains connection (input) and the load connection (output) as well as sub-D connections for the data or computer interface (COM A). The UPS unit must be charged for approximately eight hours before it is used for the first time (please consult the operation instruction and safety regulations).

Indicator and control panel

The following LEDs:

OVERLOAD
LOAD
BYPASS
INVERTER
BATTERY
LINE
ALARM

provide a visual indication of the unit's status at any given time. Various acoustic signals are generated in case of a mains failure, when the battery is low and if an overload condition or malfunction occurs. The inverter can be switched ON and OFF.

Scope of supply

The scope of supply includes:

- UPS unit
- Operating instructions, including installation and maintenance instructions, in several languages (German, English, French, Portuguese, Spanish)
- IEC 320-16 multi-socket distribution board to triple socket-outlet with earthing contact (E₁ 60 only)

- Communication packages for all major micro-computer systems and networks
- Manual bypass cubicles to allow isolation or replacement of the UPS with no disconnection of the load

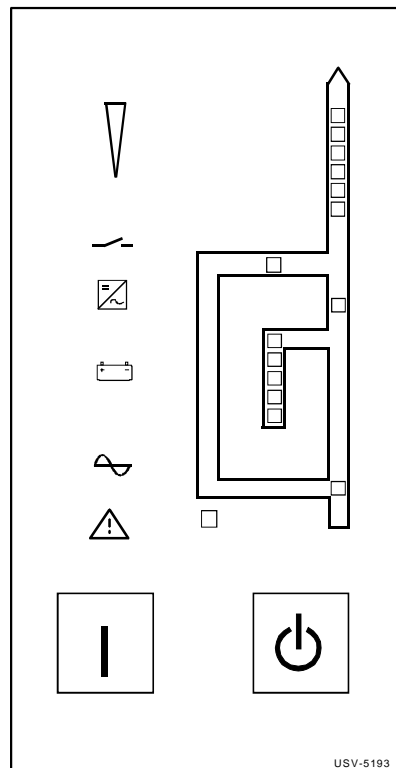







Fig 4
Indicator and control panel Series E₁

Technical data

Type	E1 60		E1 100	
Type of operation	true on-line with double conversion		true on-line with double conversion	
Nominal power (cos $\phi_{\text{ind}} = 0,7$)	kVA	6	10	
Input				
Single-phase, voltage range	V	176 to 276	176 to 276	
Frequency	Hz	50/60, $\pm 5\%$ automatic frequency recognition		
Current		Sine wave, power factor $> 0,97$		
Battery				
Type	Valve-regulated lead-acid battery			
Rated voltage	V	240	312	
Integrated battery				
Backup time	at 50% load	min	25	25
	at 100% load	min	8	8
Output				
Single-phase Voltage, frequency	220 V, 230 V, 240 V, 50/60 Hz, as input frequency			
Voltage tolerance	$\pm 2\%$			
Frequency tolerance	mains operation	Output synchronized with mains frequency		
	self-clocked	$\pm 0,5\%$		
Harmonic distortion	linear load	$< 3\%$		
	non-linear load	$< 8\%$		
Permissible crest factor	3			
Overload capability	150 % up to 10 s, 125 % up to 60 s, short-circuit-proof			
Automatic bypass	integrated			
Service-switch	integrated, manual			
Display symbols	      UPS fault Mains Battery capacity Inverter Bypass Load			
Acoustic signal	Battery operation: 4 s interval (signal resettable), battery low: 1 s interval, overload: 1 s interval, fault: continuous signal.			
Data interace				
Type	RS 232 and individual signals (level: 5 V to 12 V) and optional interface			
Unit				
Permissible ambient temperature	operation	0 °C to + 40 °C, recommended temperature: + 15 °C bis + 32 °C ¹⁾		
	storage	- 15 °C to + 40 °C		
Relative humidity	20 % to 90 %, no condensation			
Cooling	F (fan)			
Altitude	Up to 3000 m above sea level; maximum temperature above 1500 m: 35 °C			
Electrical safety	EN 50 091-1, TÜV-approved			
Radio interference level	EN 50 091-2			
Immunity	IEC 801-2 Level 4, IEC 801-3 Level 3		IEC 801-4 Level 4, IEC 801-5 Level 3	
Degree of protection	IP 20			
Efficiency	%	91	92	
Noise level	dB(A)	≤ 55	≤ 55	
Dimensions (W x H x D)	mm	260 x 705 x 605	300 x 710 x 675	
Weight	net	kg	110	
	gross	kg	125	
Colour	RAL 7035		RAL 7035	

1) If the ambient temperature is permanently higher than 20 °C, the battery service life is reduced by half for each 10 °C temperature increase.

UPS Systems Series E_I

Technical data

Type	E _I 60	E _I 100
Mains connection	Fixed-mounted	
Max. permissible conductor cross-section	mm ² 16	20
Min. conductor cross-section	mm ² 4	10
Maximum current at 230 V	A 30	49
Battery connection	3-pole plug	3-pole plug
Load connection	Fixed mounted/plug	Fixed mounted
Max. permissible conductor cross-section	mm ² 16	20
Min. conductor cross-section	mm ² 4	10
Plug connection	IEC 320, 16 A	–
Data interface	Sub-D 9-pole, male	
Required mains fuse	A 35	50

Ordering data

Type	E _I 60	E _I 100
Order No. (unit with integrated battery)	6SU50 65-2AA00	6SU50 66-2AA00
Order No. (unit without integrated battery)	6SU50 65-2AN00	6SU50 66-2AN00

Accessories

Type	BP E _I 60-2	BP E _I 100-2
Battery expansion with separate battery cubicle	For UPS E _I 60	For UPS E _I 100
Backup time	min 25	25
Dimensions (B x H x T)	mm 260 x 705 x 605	300 x 710 x 675
Weight net/gross	kg 130/145	164/180
Connections via battery recharging, e. g. during storage	Cable enclosed After 3 months at the latest	Cable enclosed After 3 months at the latest
Order No.	6SU54 13-2KA01	6SU54 13-2PA01

Technical data

Type	E1 100-3		E1 200-3
Type of operation	True on-line with double conversion		True on-line with double conversion
Nominal power (cos $\phi_{ind} = 0,7$)	kVA	10	20
Input			
Three-phase, voltage range	V	304 to 478	304 to 478
Frequency	Hz	50/60, $\pm 5\%$ automatic frequency recognition	
Current		Sine wave, power factor $> 0,95$	
Battery			
Type	Valve-regulated lead-acid battery		
Rated voltage	V	312	240
Integrated battery			
Backup time	at 50% load	min	25
	at 100% load	min	8
Output			
Single-phase Voltage, frequency	220 V, 230 V, 240 V, 50/60 Hz, as input frequency		
Voltage tolerance	$\pm 2\%$		
Frequency tolerance	mains operation	Output synchronized with mains frequency	
	self-clocked	$\pm 0,5\%$	
Harmonic distortion	linear load	$< 3\%$	
	non-linear load	$< 8\%$	
Permissible crest factor	3		
Overload capability	150 % up to 10 s, 125 % up to 60 s, short-circuit-proof		
Automatic bypass	integrated		
Service-switch	integrated, manual		
Display symbols	 <small>UPS fault M a i n s B a t t e r y c a p a c i t y I n v e r t e r B y p a s s L o a d</small>		
Acoustic signal	Battery operation: 4 s interval (signal resettable), battery low: 1 s interval, overload: 1 s interval, fault: continuous signal .		
Data interace			
Type	RS 232 and individual signals (level: 5 V to 12 V) and optional interface		
Unit			
Permissible ambient temperature	operation	0 °C to + 40 °C, recommended temperature: + 15 °C bis + 32 °C ¹⁾	
	storage	- 15 °C to + 40 °C	
Relative humidity	20 % to 90 %, no condensation		
Cooling	F (fan)		
Altitude	Up to 3000 m above sea level; maximum temperature above 1500 m: 35 °C		
Electrical safety	EN 50 091-1, TÜV-approved		
Radio interference level	EN 50 091-2		
Immunity	IEC 801-2 Level 4, IEC 801-3 Level 3		IEC 801-4 Level 4, IEC 801-5 Level 3
	IEC 801-4 Level 4, IEC 801-5 Level 4		
Degree of protection	IP 20		
Efficiency	%	92	91
Noise level	dB(A)	≤ 55	≤ 60
Dimensions (W x H x D)	mm	300 x 710 x 675	420 x 1180 x 800
Weight	net	kg	325
	gross	kg	346
Colour	RAL 7035		RAL 7035

1) If the ambient temperature is permanently higher than 20 °C, the battery service life is reduced by half for each 10 °C temperature increase.

UPS Systems Series E1

Technical data

Type	E1 100-3	E1 200-3
Mains connection	Fixed-mounted	
Max. permissible conductor cross-section	mm ² 16	35
Min. conductor cross-section	mm ² 10	35
Maximum current at 230 V	A 49	92
Battery connection	3-pole plug	
Load connection 1 AC/N)	Fixed mounted	
Max. permissible conductor cross-section	mm ² 16	35
Min. conductor cross-section	mm ² 10	35
Maximum current at 230 V	A 49	96
Data interface	Sub-D 9-pole, male	
Required mains fuse	A 50	100

Order data

Type	E1 100-3	E1 200-3
Order No. (unit with integrated battery)	6SU51 10-2BA00	6SU51 20-2BA00
Order No. (unit without integrated battery)	6SU51 10-2BN00	6SU51 20-0BN00

Accessories

Type	BP E1 100-2	BP E1 200-2
Separate battery cubicle		
Battery expansion with separate battery cubicle	6SU51 10-2BN00	6SU51 20-2BN00
Backup time	min 25	27
Dimensions (B x H x T)	mm 300 x 710 x 675	420 x 1180 x 800
Weight net/gross	kg 164/185	420/445
Order No.	6SU54 13-2PA01	6SU54 13-2TA01
Service switch	HU-E-50 A	HU-E-100 A
Order No.	6SU55 33-0CA00	6SU55 33-0EA00

Dimensions

UPS units

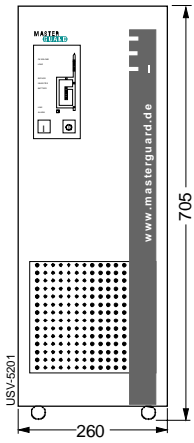

Depth 605

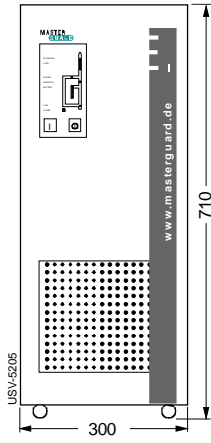

Depth 675

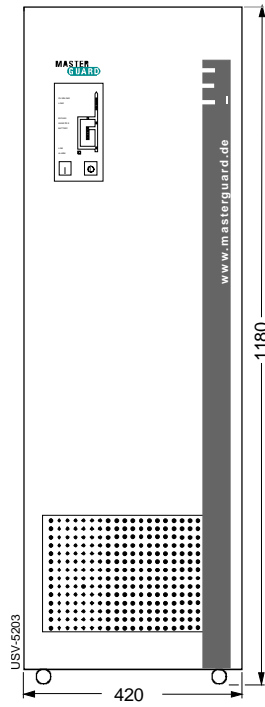

Depth 800

UPS
E_i 60

UPS
E_i 100 / E_i 100-3

UPS
E_i 200-3

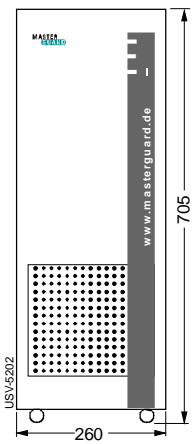

Depth 605

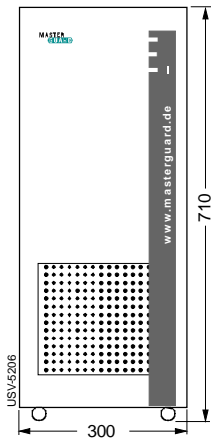

Depth 675

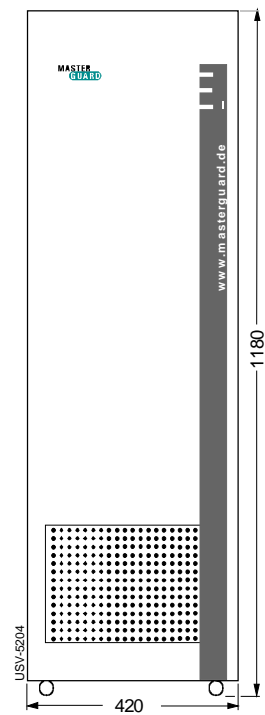

Depth 800

Battery pack
BP E_i 60

Battery pack
BP E_i 100-2

Battery pack
BP E_i 200-2

All dimensions in mm

UPS Systems Series E1

Condition of Sale and Delivery

Outside Germany:

Subject to the General Conditions of Supply and Delivery for Products and Services of the Electrical and Electronic Industry and to any other conditions agreed upon with the recipients of Masterguard pricelists.

The technical data, dimensions and weights are subject to change unless otherwise stated on the individual pages of this catalog.

The illustrations are for reference only. We reserve the right to adjust the prices and shall charge the prices applying on the date of delivery.